

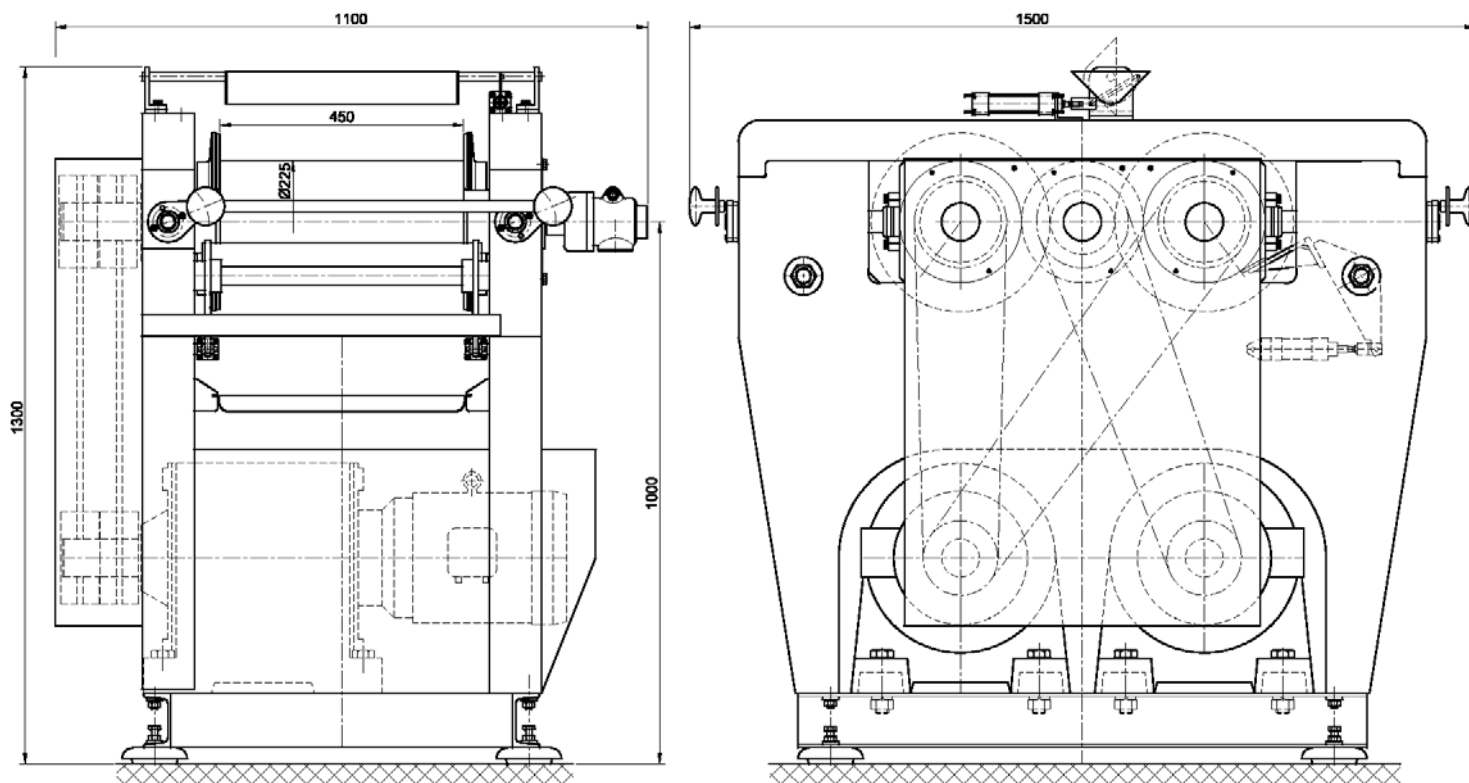

21.08/10.4.1

## LABORATORY THREE-ROLL MILLS (Two “two-roll mills” )



### **Features of work:**

- as differential two-roll mills (drainage and pregelatinization)
- as homokinetic two-roll mills (drainage and gelatinization)

### **Technical Data:**

- application: testings in manufacturing of NC powder
- rollers diameter..... 225 mm
- working length ..... 450 mm
- RPM ..... (8÷25) min<sup>-1</sup>
- end roller movement ..... manually
- friction:
  - at differential ..... optional
  - at homokinetic ..... 1:1
- feeding two-roll mills:
  - at differential ..... semiautomatic
  - at homokinetic ..... manually
- tempering of two-roll mills ..... hot water (20÷95)C°
- EM power ..... 2x7,5 kW

**TECOOP-ENG D.O.O.**

INDUSTRIJSKI INŽENJERING

Srbija-26000 PANČEVO, Savska 12-14  
Tel +381 13 346226 Tel/Fax +381 13 346042  
www.tecoop.co.rs / tecoop@sezampro.rs